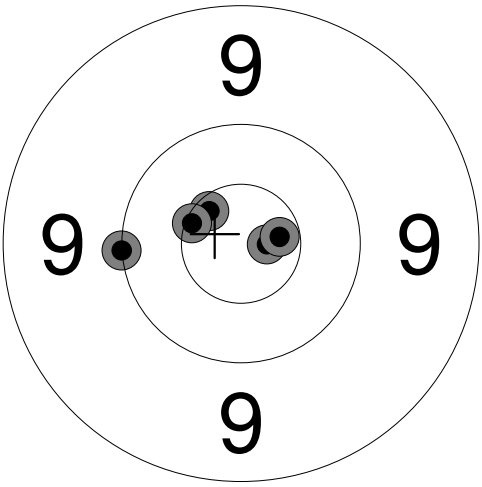
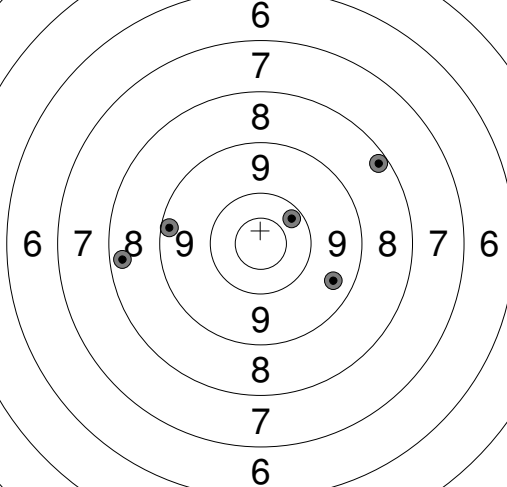
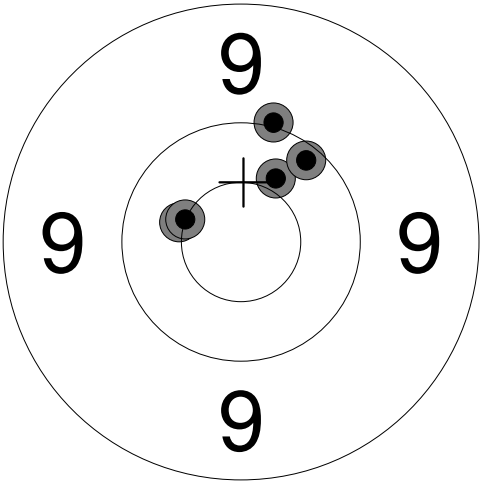
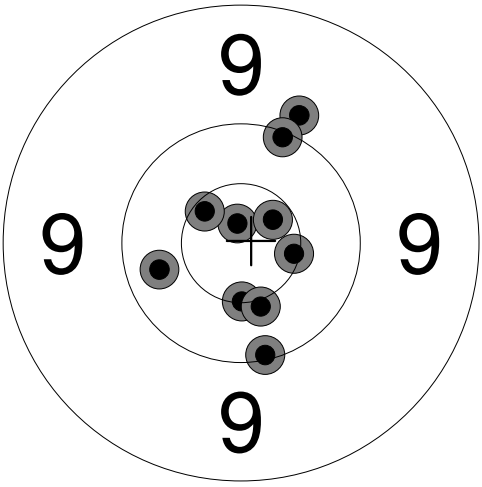
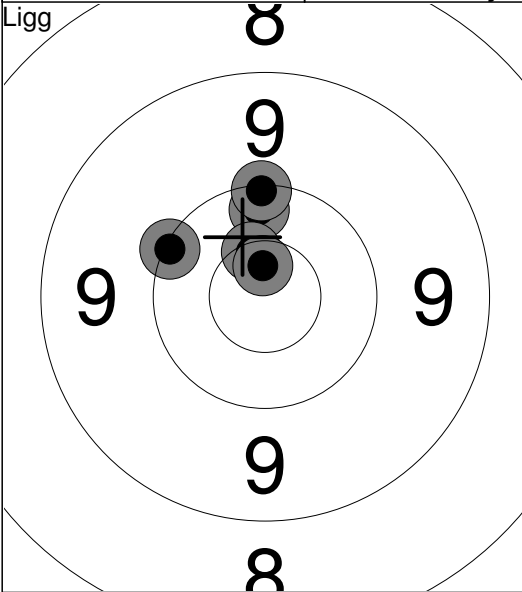
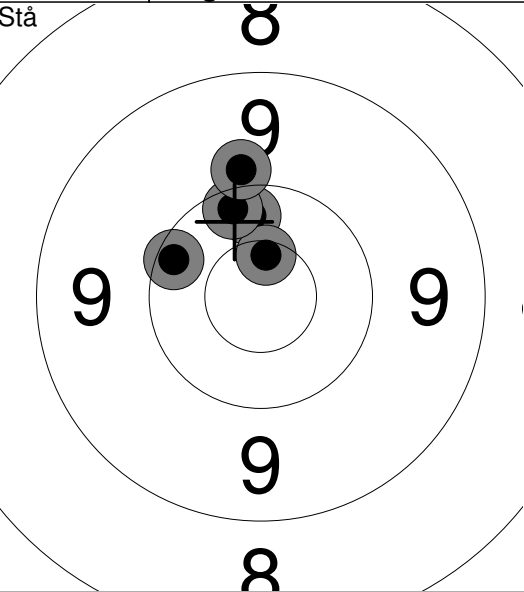
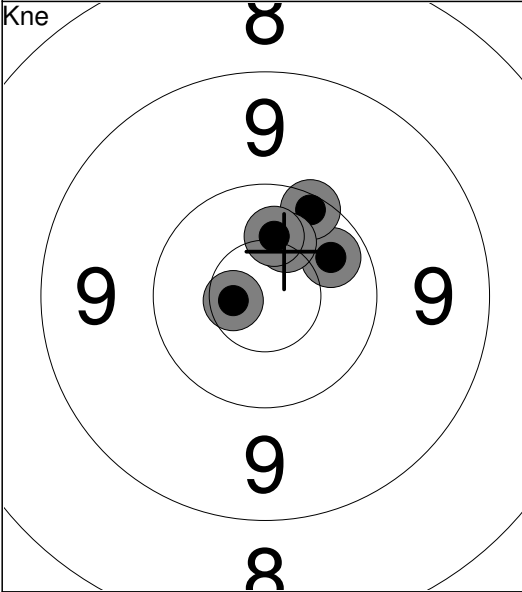
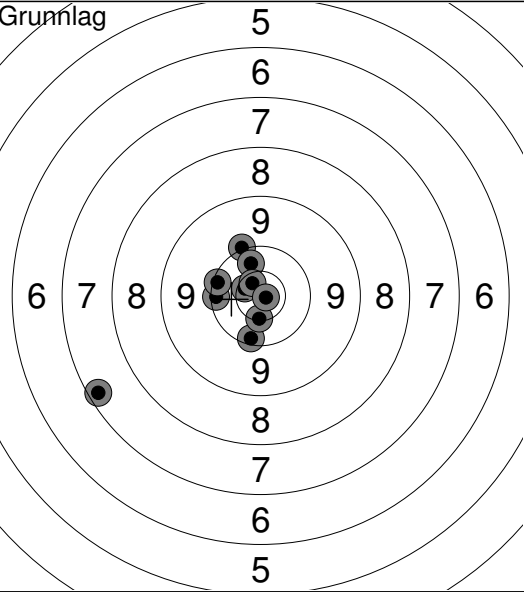

<p>Ligg</p> 	<p>Stå</p> 	<p>1: 8.2 ↗ 2: 10.2 ↗ 3: 9.2 ← 4: 8.3 ← 5: 9.4 ⇒</p>
<p>Serie 50.0</p> <p>Total 50.0</p>	<p>Serie 44.0</p> <p>Total 94.0</p>	

<p>Kne</p> 	<p>Grunnlag</p> 	<p>1: 10.4 ↑ 2: *10.5 ↙ 3: 10.0 ↑ 4: 10.2 ↗ 5: *10.5 ↙</p>
<p>Serie 50.0</p> <p>Total 144.0</p>	<p>Serie 96.0</p> <p>Total 240.0</p>	

<p>Finale</p> 	<p>1: *10.5 ↓ 2: *10.9 ↑ 3: 9.9 ↑ 4: *10.7 ↗ 5: 10.1 ↑ 6: *10.6 ⇒ 7: *10.6 ↙ 8: *10.5 ↓ 9: 10.3 ← 10: 10.1 ↓</p>	
<p>Serie 99.0</p> <p>Total 339.0</p>		

<p>Ligg</p> 	<p>Stå</p> 	
<p>1: 10.3 ↑</p> <p>2: 10.1 ↙</p> <p>3: *10.7 ↑</p> <p>4: *10.8 ↑</p> <p>5: 10.1 ↑</p>	<p>1: 10.4 ↑</p> <p>2: *10.7 ↑</p> <p>3: 10.3 ↑</p> <p>4: 9.9 ↑</p> <p>5: 10.2 ↙</p>	
Serie 50.0	Serie 49.0	
Total 50.0	Total 99.0	

<p>Kne</p> 	<p>Grunnlag</p> 	
<p>1: 10.4 ↗</p> <p>2: 10.2 ↑</p> <p>3: *10.6 ↑</p> <p>4: *10.5 ↑</p> <p>5: *10.8 ↙</p>	<p>1: 10.0 ↑</p> <p>2: 10.4 ↑</p> <p>3: *10.7 ↙</p> <p>4: *10.8 ↙</p> <p>5: 10.2 ↓</p> <p>6: *10.6 ↓</p> <p>7: 10.2 ←</p> <p>8: *10.9 →</p> <p>9: 10.2 ←</p> <p>10: 7.3 ↙</p>	
Serie 50.0	Serie 97.0	
Total 149.0	Total 246.0	

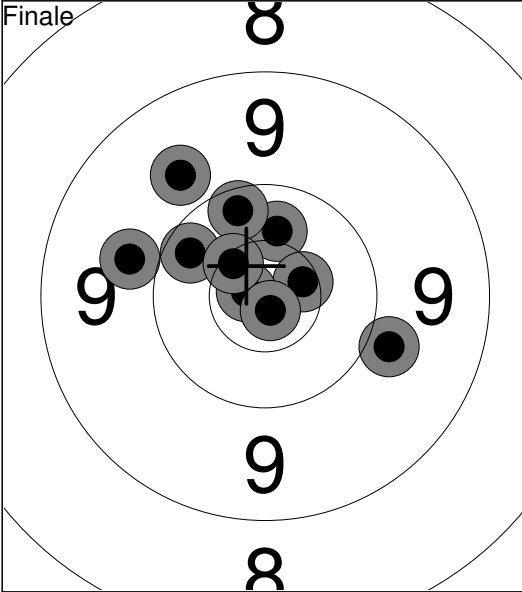
<p>Finale</p> 		
<p>1: *10.5 ↑</p> <p>2: 10.3 ↙</p> <p>3: *10.7 →</p> <p>4: 10.3 ↑</p> <p>5: 9.8 ↗</p> <p>6: 9.9 →</p> <p>7: 9.8 ←</p> <p>8: *10.9 ↙</p> <p>9: *10.7 ↙</p> <p>10: *10.9 ↓</p>		
Serie 97.0		
Total 343.0		

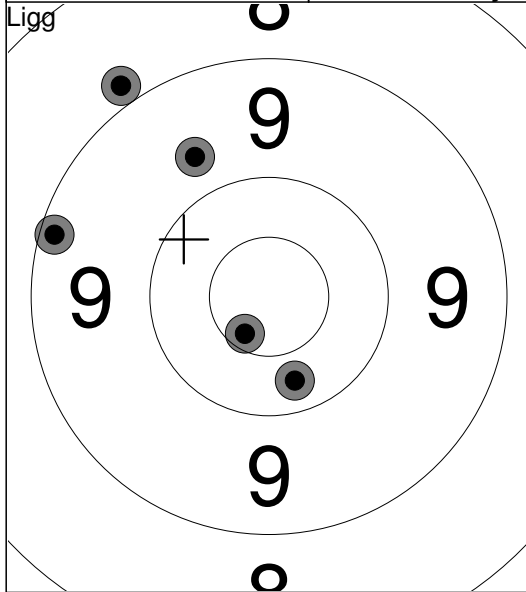

1: 8.9 ↗
2: 9.2 ←
3: *10.7 ↘
4: 10.3 ↘
5: 9.7 ↗
Serie 46.0
Total 46.0

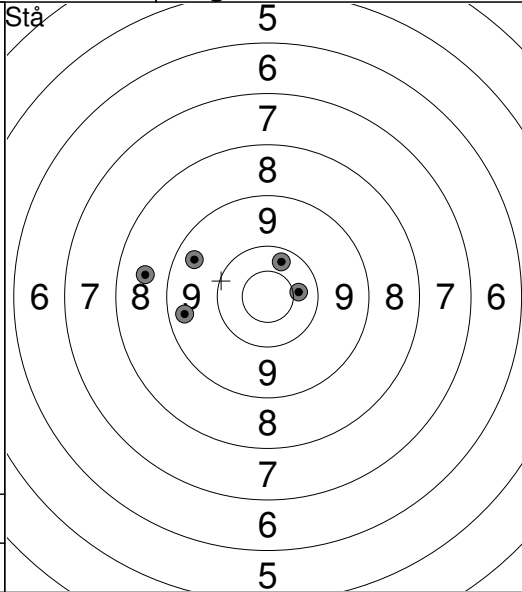

1: 9.4 ↖
2: 8.6 ←
3: 10.4 →
4: 10.3 ↗
5: 9.4 ←
Serie 46.0
Total 92.0

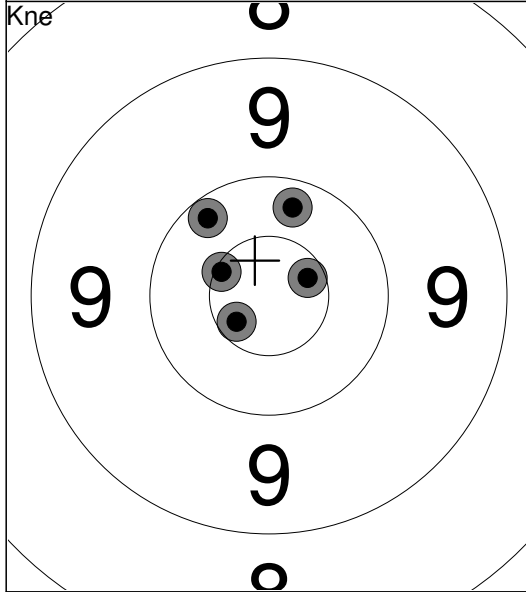

1: 10.3 ↗
2: *10.7 →
3: 10.2 ↖
4: *10.7 ↘
5: *10.6 ↖
Serie 50.0
Total 142.0

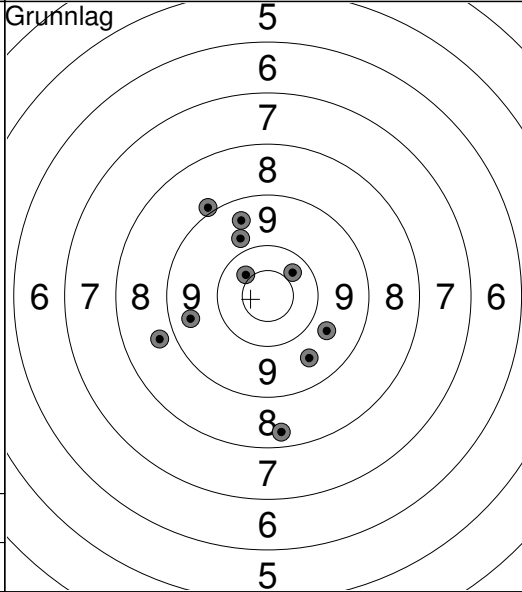

1: 9.6 ↘
2: 8.9 ↗
3: 8.3 ↘
4: 9.4 ←
5: 8.7 ←
6: 9.8 ↗
7: 9.5 ↗
8: 9.7 ↘
9: 10.4 ↗
10: 10.4 ↖
Serie 89.0
Total 231.0

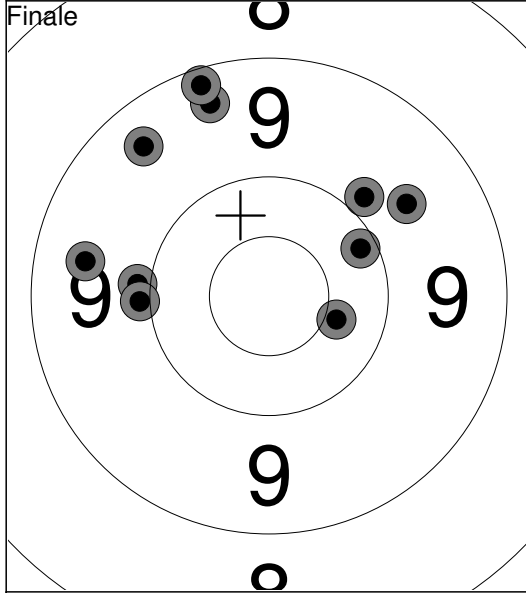

1: 9.3 ↗
2: 9.2 ↗
3: 9.9 ←
4: 10.2 →
5: 9.5 ←
6: 9.4 ↗
7: 9.9 ↗
8: 9.9 ←
9: 9.6 ↗
10: 10.4 →
Serie 92.0
Total 323.0

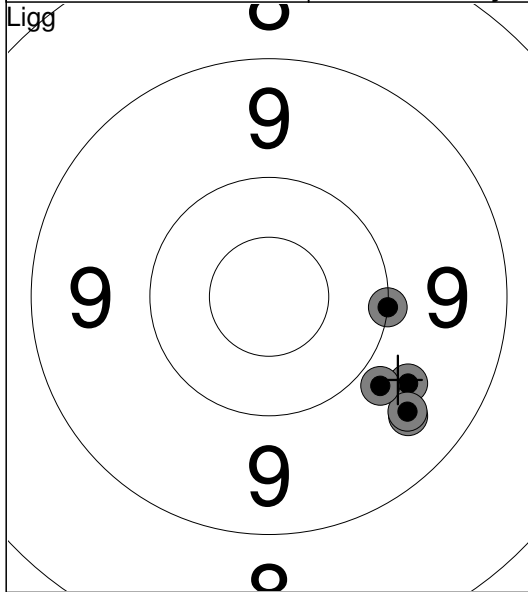

1: 9.7 ↘	
2: 9.5 ↘	
3: 9.5 ↘	
4: 10.0 →	
5: 9.8 ↘	
Serie 46.0	
Total 46.0	

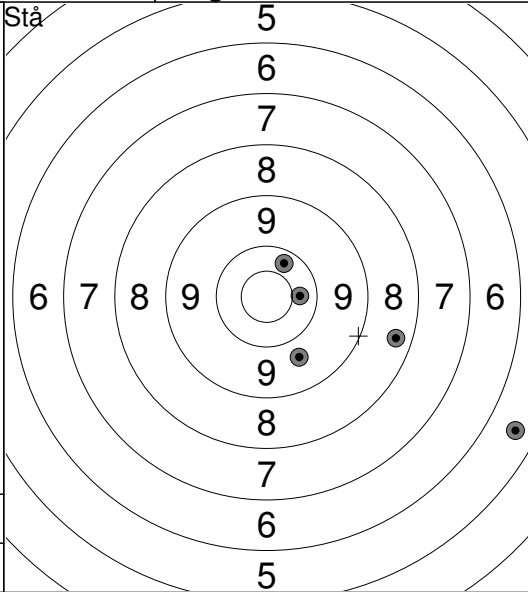

1: 5.5 ↘	
2: 9.7 ↘	
3: 10.3 ↗	
4: 8.4 →	
5: 10.4 →	
Serie 42.0	
Total 88.0	

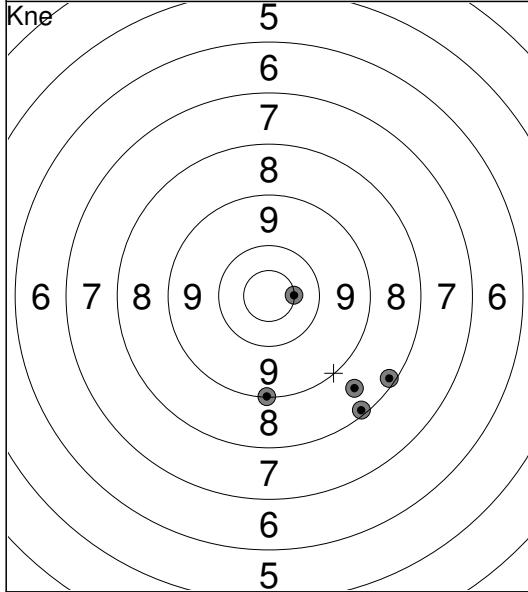

1: 8.6 ↘	
2: 8.2 ↘	
3: 9.0 ↓	
4: 8.1 ↘	
5: *10.5 →	
Serie 43.0	
Total 131.0	

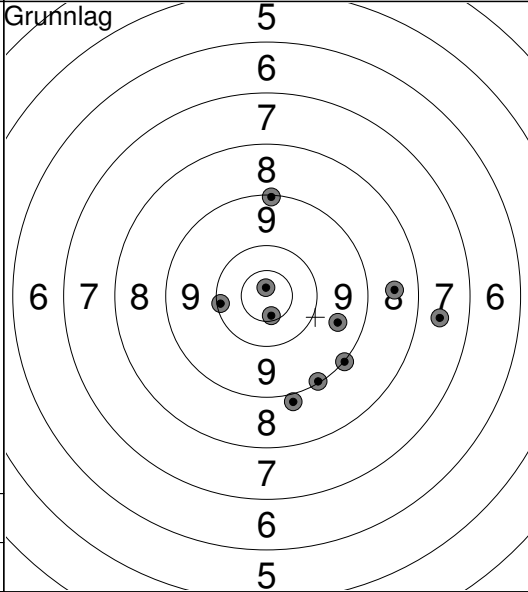

1: *10.9 ↗	
2: 10.1 ←	
3: 7.6 →	
4: 9.1 ↑	
5: 9.0 ↘	
6: 8.5 →	
7: *10.6 ↓	
8: 9.1 ↘	
9: 9.5 →	
10: 8.9 ↓	
Serie 89.0	
Total 220.0	

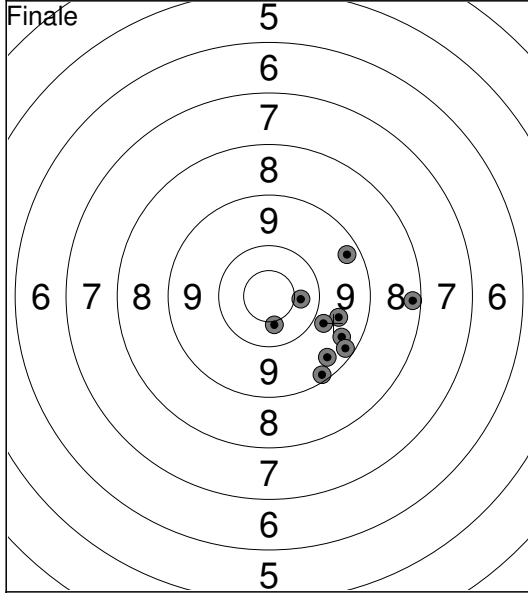

1: *10.5 ↓	
2: 9.4 ↘	
3: 9.6 →	
4: 9.4 ↘	
5: 9.2 ↘	
6: 9.3 →	
7: 9.8 ↘	
8: 8.2 →	
9: 9.2 ↘	
10: 10.4 →	
Serie 91.0	
Total 311.0	

<p>Ligg</p>	<p>Stå</p>	<p>1: 10.4 ↖ 2: 10.4 ↙ 3: *10.6 ↙ 4: *10.8 ↗ 5: 10.4 ↓</p>	<p>1: 9.8 ↑ 2: 10.0 ↙ 3: 8.0 ← 4: 8.5 ↓ 5: 9.5 ↖</p>
Serie 50.0		Serie 44.0	
Total 50.0		Total 94.0	

<p>Kne</p>	<p>Grunnlag</p>	<p>1: *10.9 ↑ 2: 10.1 ↖ 3: 10.0 ↗ 4: 9.8 ↗ 5: 9.9 ↙</p>	<p>1: 7.3 → 2: 10.4 ↑ 3: 9.4 ← 4: 9.9 ↖ 5: 9.8 ↑ 6: 8.3 ↖ 7: 9.7 ↑ 8: *10.5 → 9: *10.5 → 10: *10.5 ↓</p>
Serie 48.0		Serie 91.0	
Total 142.0		Total 233.0	

<p>Finale</p>	<p>1: *10.7 ↑ 2: 9.7 ↓ 3: 9.9 ↓ 4: 10.3 ↓ 5: 9.8 ↓ 6: 10.2 ↗ 7: 10.2 ↓ 8: 9.9 → 9: 10.4 ↙ 10: *10.7 →</p>		
Serie 96.0			
Total 329.0			

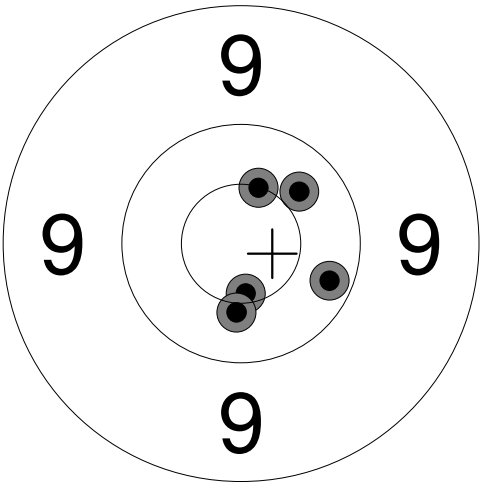
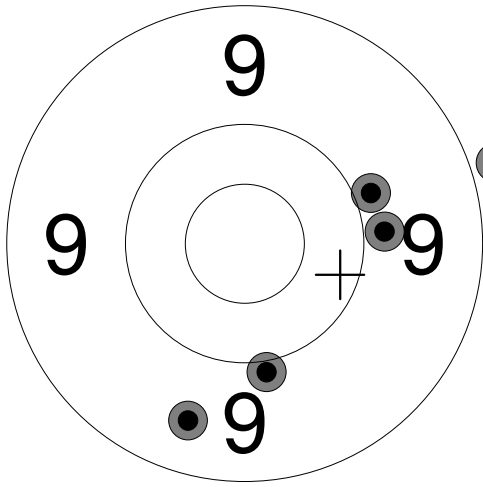
<p>Ligg</p> 	<p>Stå</p> 	<p>1: 10.2 →</p> <p>2: 10.4 ↗</p> <p>3: *10.5 ↗</p> <p>4: *10.6 ↓</p> <p>5: 10.4 ↓</p>	<p>1: 9.9 →</p> <p>2: 9.9 ↓</p> <p>3: 8.8 →</p> <p>4: 9.5 ↓</p> <p>5: 9.9 →</p>
Serie 50.0		Serie 44.0	
Total 50.0		Total 94.0	

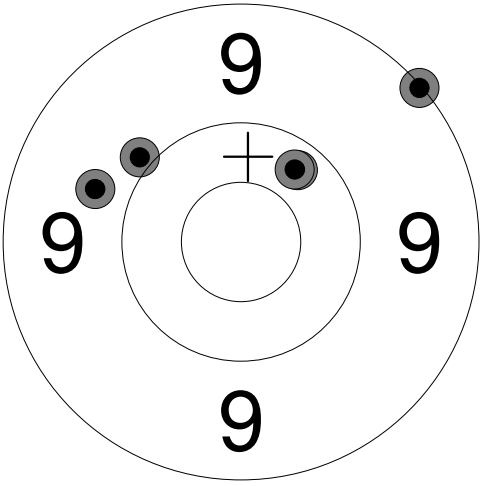
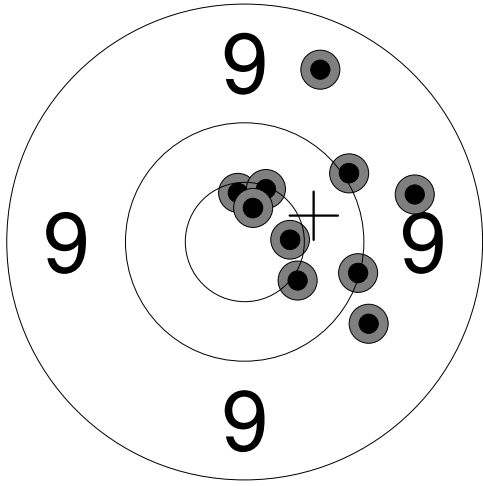
<p>Kne</p> 	<p>Grunnlag</p> 	<p>1: 9.0 ↗</p> <p>2: 10.3 ↗</p> <p>3: 9.9 ↖</p> <p>4: 9.7 ↖</p> <p>5: 10.3 ↗</p>	<p>1: 9.4 ↗</p> <p>2: 10.0 ↗</p> <p>3: 9.8 ↘</p> <p>4: 10.0 →</p> <p>5: 9.5 →</p> <p>6: *10.6 ↗</p> <p>7: *10.6 ↗</p> <p>8: *10.5 ↘</p> <p>9: *10.7 ↗</p> <p>10: *10.6 →</p>
Serie 47.0		Serie 97.0	
Total 141.0		Total 238.0	

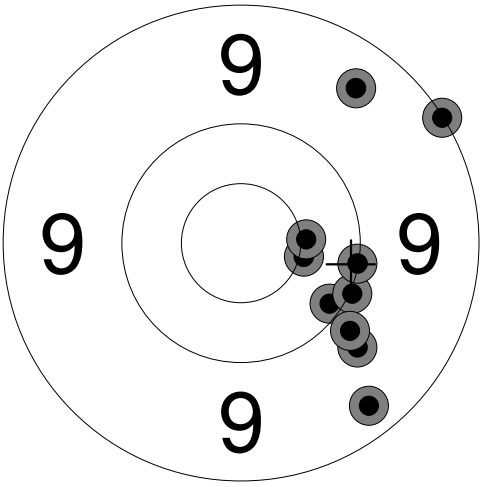
<p>Finale</p> 	<p>1: 9.4 ↗</p> <p>2: 9.0 ↗</p> <p>3: *10.5 →</p> <p>4: *10.5 →</p> <p>5: 10.1 ↓</p> <p>6: 10.0 ↓</p> <p>7: 10.0 →</p> <p>8: 9.3 ↓</p> <p>9: 9.7 ↓</p> <p>10: 9.9 ↓</p>		
Serie 95.0			
Total 333.0			

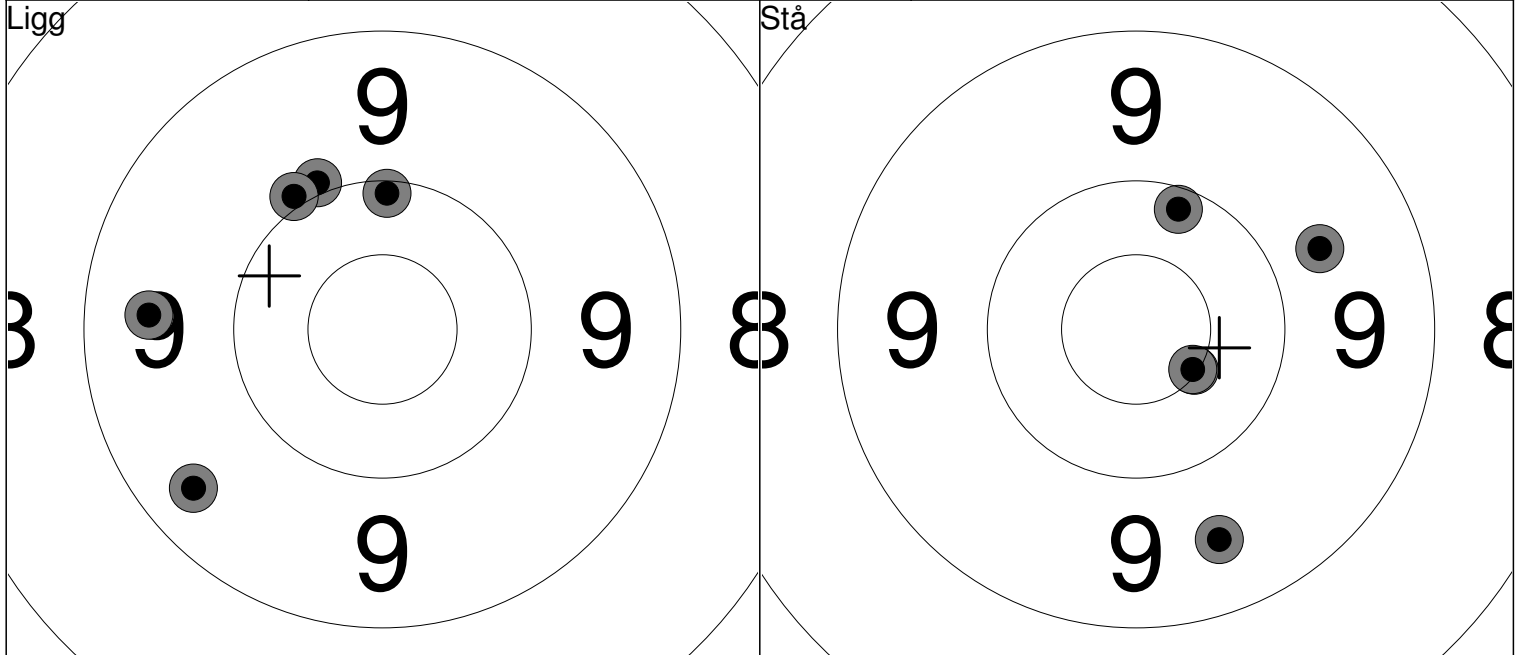

1: 10.0 ↗
2: 10.0 ↗
3: 9.5 ←
4: 10.1 ↑
5: 9.4 ↙

Serie	48
Total	48

1: *10.6 ↘
2: *10.6 ↘
3: 10.2 ↗
4: 9.5 ↘
5: 9.7 →

Serie	48
Total	96

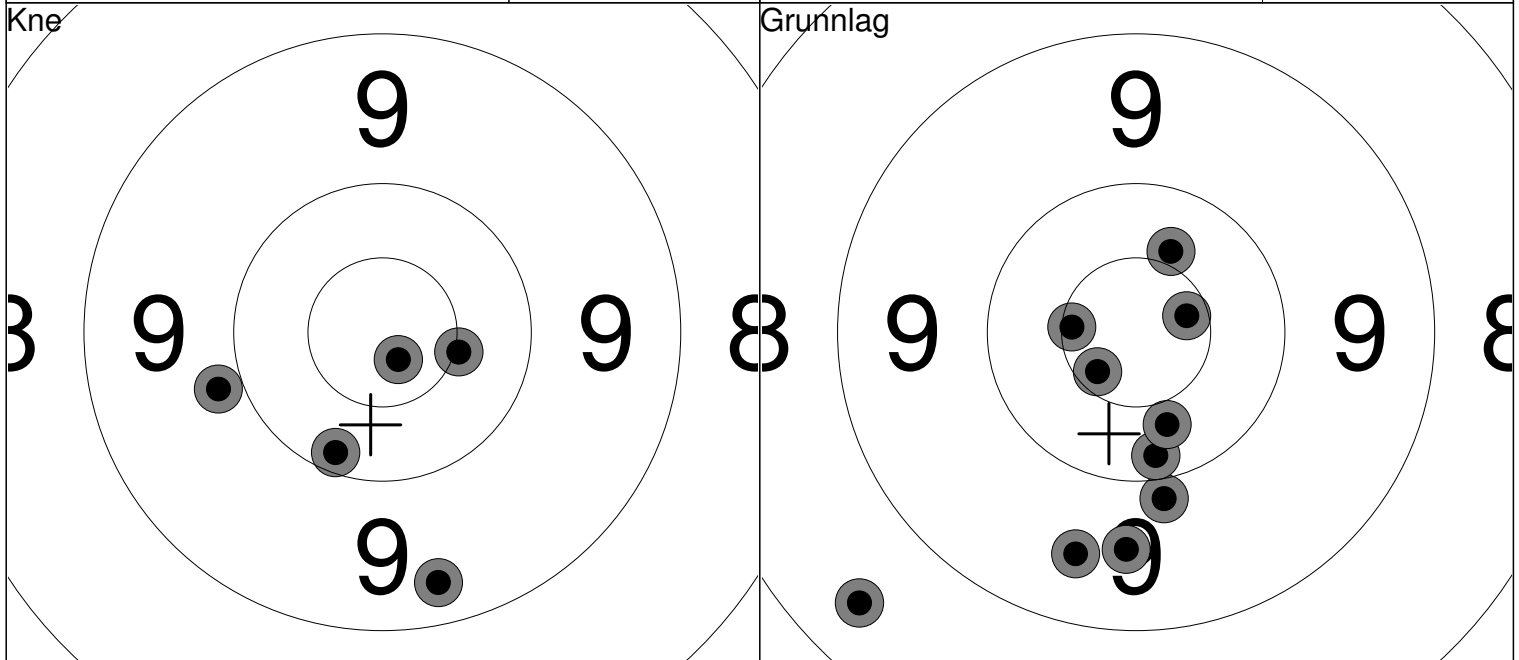

1: 10.2 ↘
2: 9.9 ←
3: *10.8 ↘
4: *10.5 →
5: 9.3 ↘

Serie	48
Total	144

1: 10.4 ↗	6: *10.6 ←
2: *10.7 →	7: 10.4 ↘
3: 9.9 ↘	8: *10.7 ↘
4: 9.6 ↘	9: 9.5 ↘
5: 10.2 ↘	10: 8.4 ↙

Serie	95
Total	239

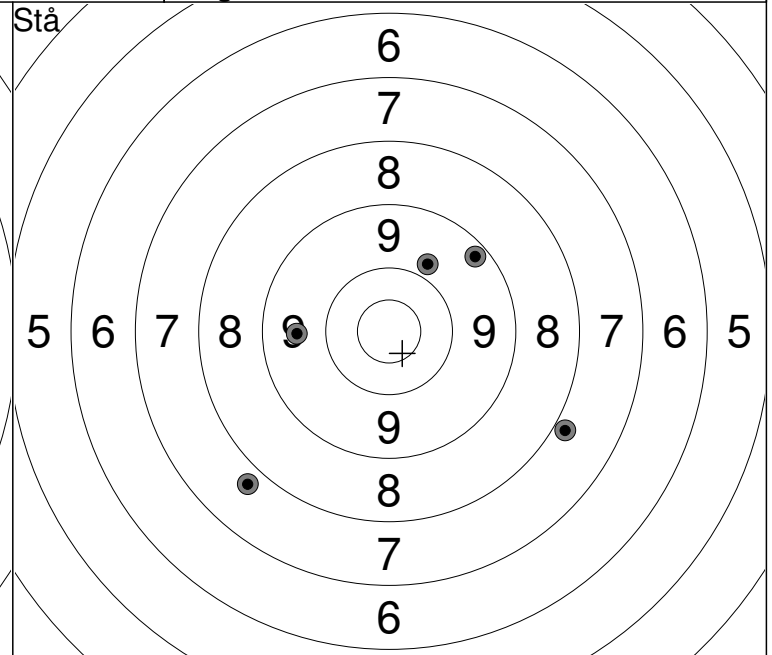
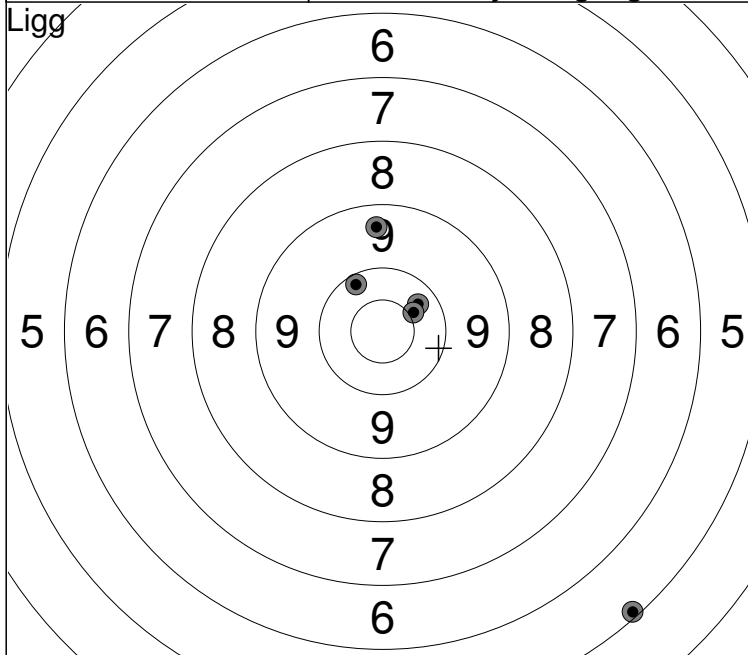

1:	10.3	↗
2:	*10.5	↗
3:	10.2	↗
4:	9.4	↑
5:	5.1	↘

Serie	44
Total	44

1:	9.8	↗
2:	9.6	←
3:	7.8	↘
4:	7.8	↙
5:	9.2	↗

Serie	41
Total	85

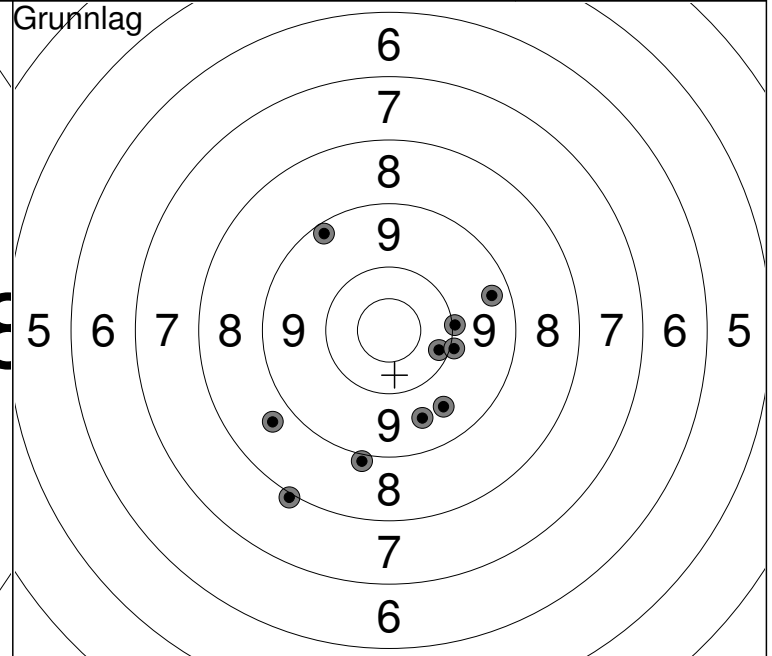
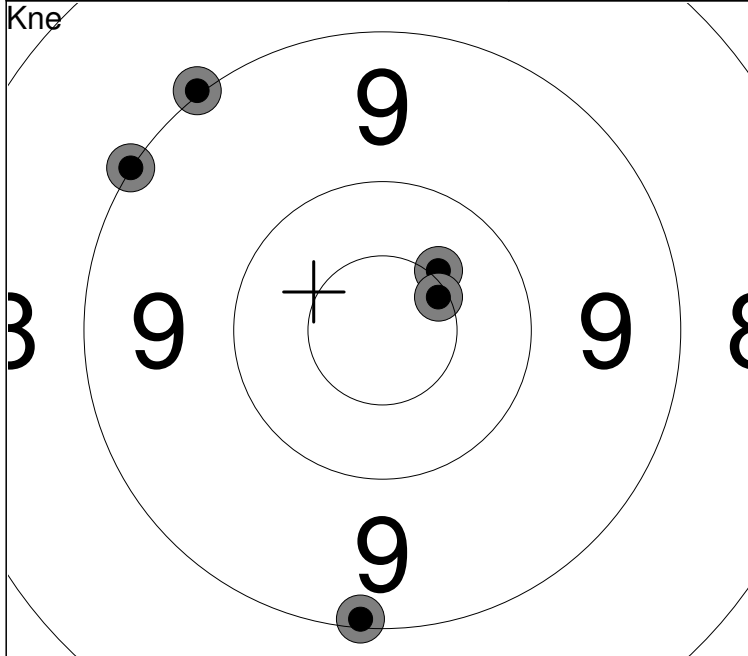

1:	*10.5	↗
2:	9.0	↗
3:	9.0	↖
4:	*10.6	↗
5:	9.1	↓

Serie	47
Total	132

1:	10.0	→
2:	9.3	→
3:	8.0	↘
4:	10.2	↘
5:	9.2	↗

6:	10.0	→
7:	8.9	↓
8:	9.6	↓
9:	8.7	←
10:	9.6	↓

Serie	90
Total	222

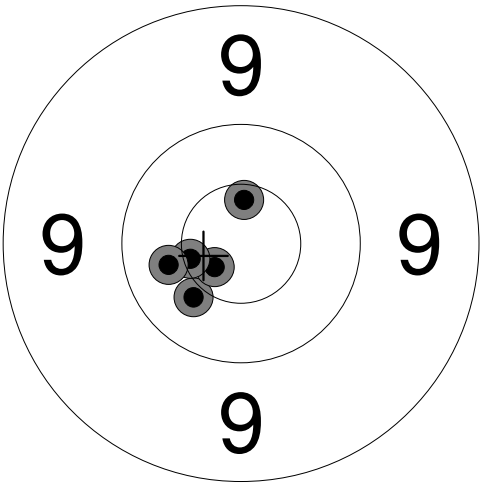
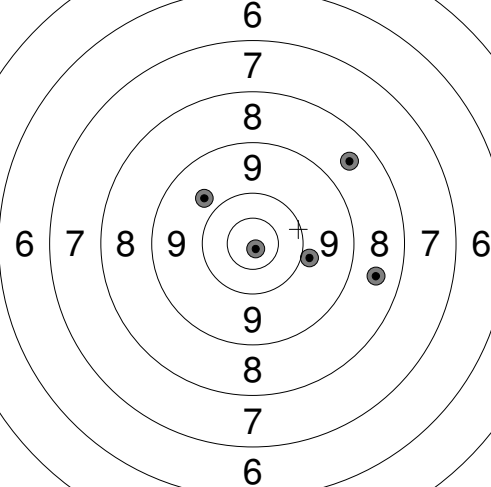
<p>Ligg</p> 	<p>Stå</p> 	<p>1: 8.5 →</p> <p>2: 9.7 ↖</p> <p>3: 8.5 ↗</p> <p>4: 9.9 →</p> <p>5: *10.9 ↘</p>
Serie 50.0	Serie 44.0	
Total 50.0	Total 94.0	

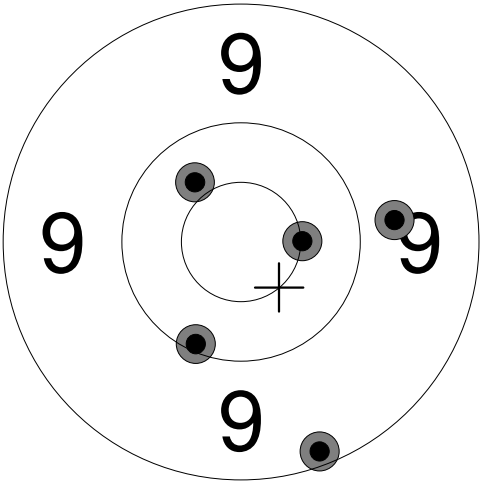
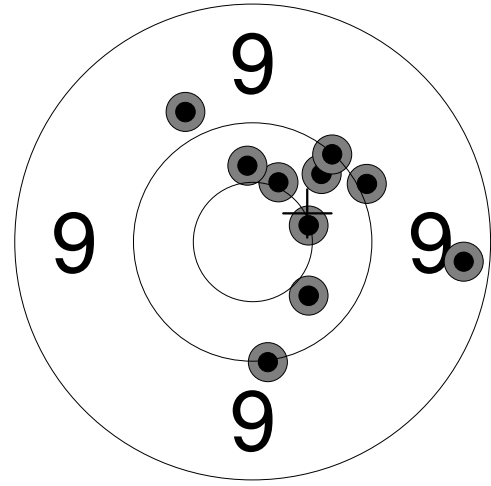
<p>Kne</p> 	<p>Grunnlag</p> 	<p>1: 10.4 ↖</p> <p>2: 9.7 →</p> <p>3: 10.1 ↘</p> <p>4: *10.5 →</p> <p>5: 9.2 ↘</p>
Serie 48.0	Serie 98.0	
Total 142.0	Total 240.0	

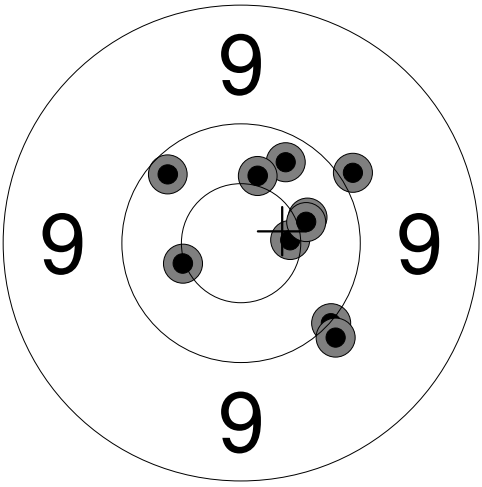
<p>Finale</p> 	<p>1: 10.2 ↖</p> <p>2: 10.4 →</p> <p>3: *10.6 →</p> <p>4: 10.0 ↘</p> <p>5: 9.9 ↗</p> <p>6: 9.9 ↘</p> <p>7: 10.3 ↗</p> <p>8: *10.5 ↗</p> <p>9: *10.5 →</p> <p>10: *10.5 ↖</p>	
Serie 98.0		
Total 338.0		

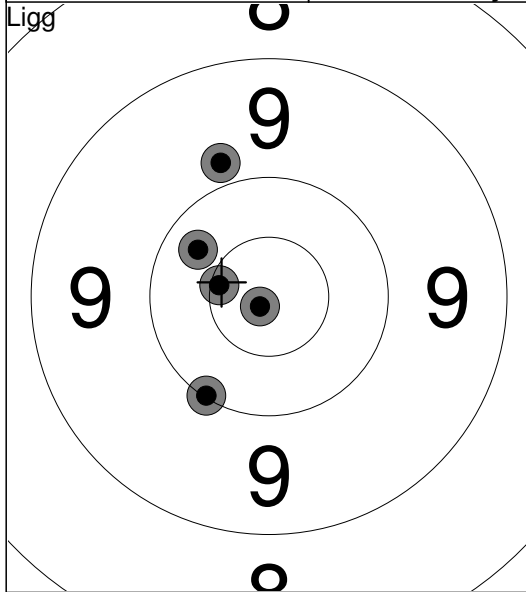

1: 9.8 ↗	
2: *10.9 ↙	
3: 10.3 ↖	
4: *10.6 ↖	
5: 10.0 ↘	
Serie 49.0	
Total 49.0	

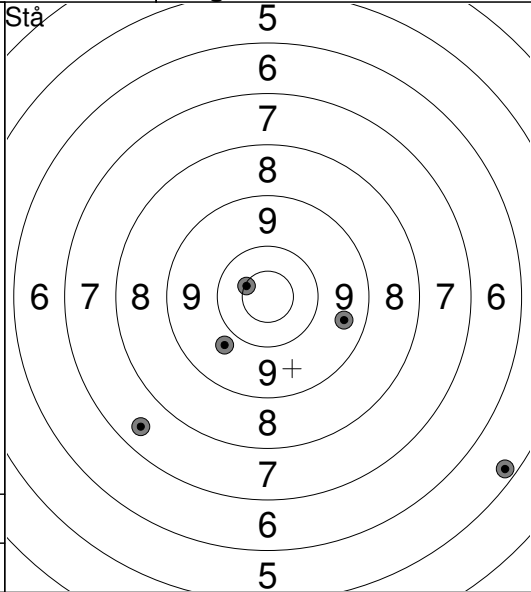

1: 9.8 ↙	
2: 7.4 ↙	
3: *10.6 ↖	
4: 5.3 ↘	
5: 9.5 →	
Serie 40.0	
Total 89.0	

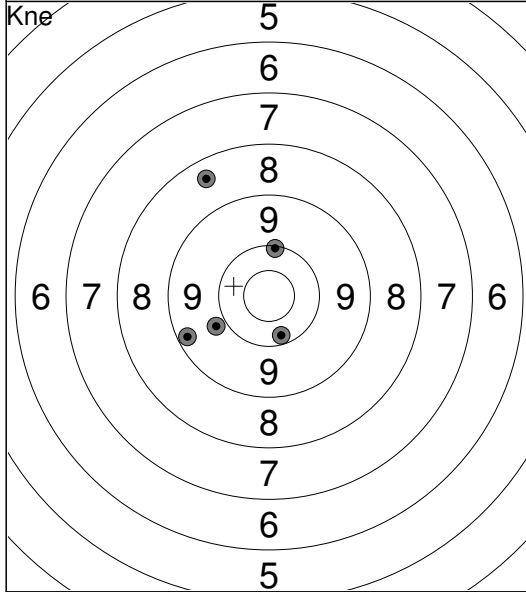

1: 10.1 ↗	
2: 8.4 ↗	
3: 9.8 ↙	
4: 10.2 ↘	
5: 9.2 ↙	
Serie 46.0	
Total 135.0	

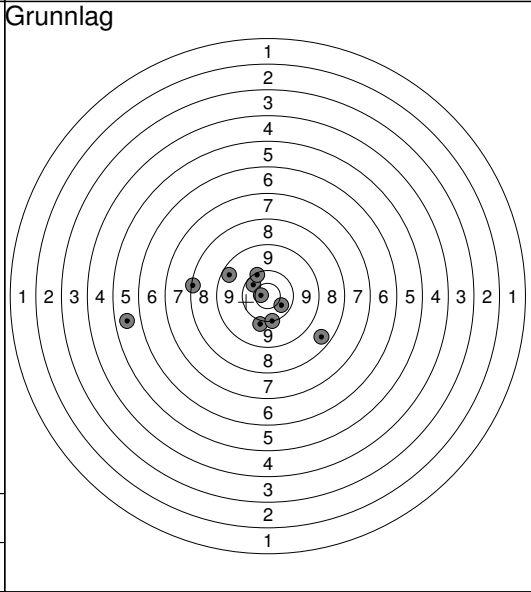

1: 10.4 ↘	
2: 5.5 ←	
3: 8.4 ↘	
4: 8.1 ←	
5: 10.3 ↗	
6: 9.3 ↗	
7: *10.8 ↖	
8: 9.9 ↘	
9: 10.1 ↘	
10: 10.1 ↗	
Serie 89.0	
Total 224.0	

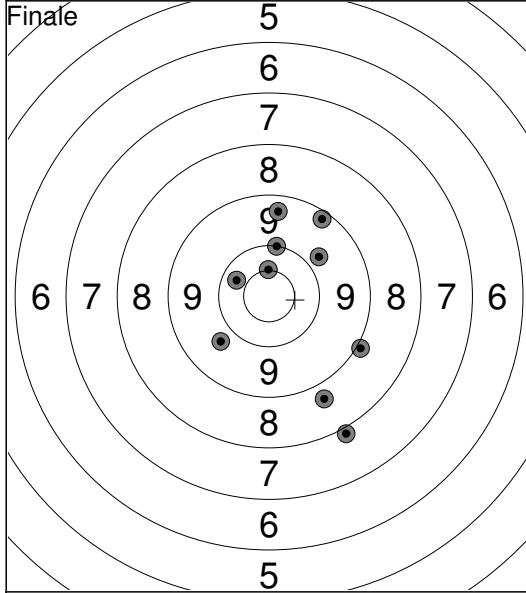

1: 9.8 ↗	
2: 10.3 ↖	
3: *10.5 ↗	
4: 7.9 ↘	
5: 9.4 ↗	
6: 9.0 →	
7: 9.7 ↙	
8: 8.7 ↘	
9: 9.2 ↗	
10: 10.0 ↗	
Serie 90.0	
Total 314.0	

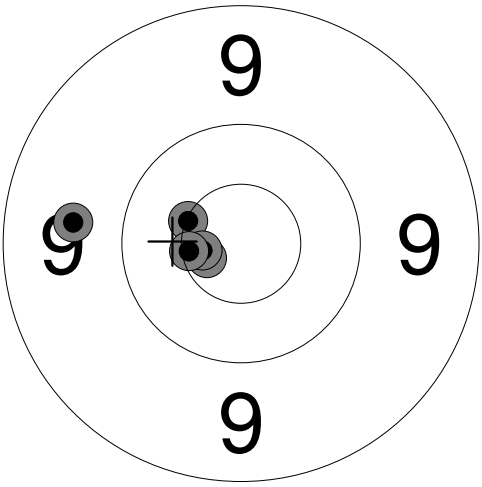
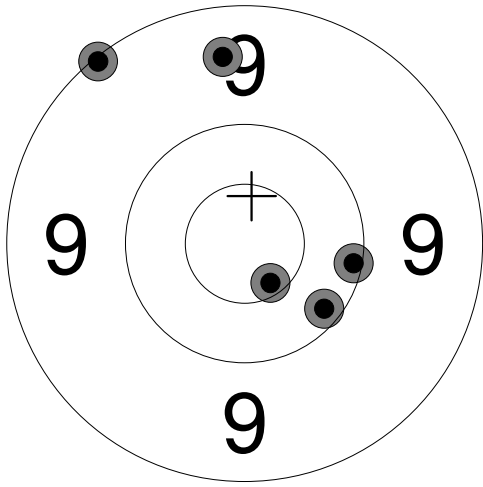
<p>Ligg</p> 	<p>Stå</p> 	
<p>1: *10.5 ↙ 2: 9.6 ← 3: *10.7 ↙ 4: *10.7 ↙ 5: *10.6 ↙</p>	<p>1: *10.6 ↘ 2: 10.2 ↘ 3: 9.5 ↑ 4: 9.1 ↗ 5: 10.1 →</p>	
Serie 49.0	Serie 48.0	
Total 49.0	Total 97.0	

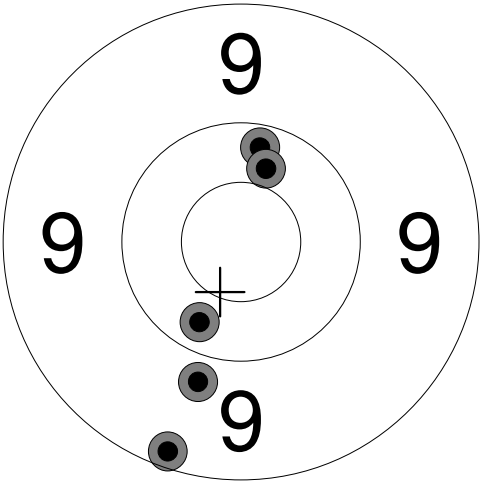
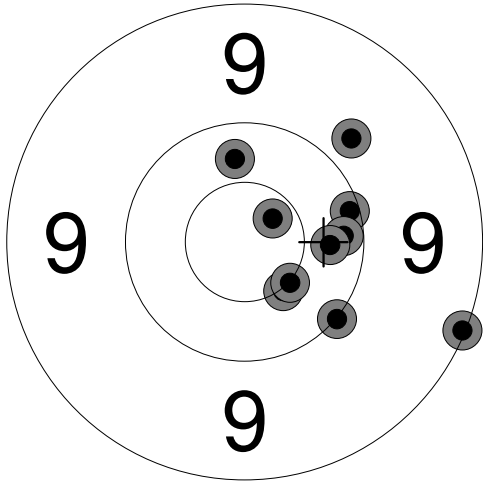
<p>Kne</p> 	<p>Grunnlag</p> 	
<p>1: 10.2 ↑ 2: 9.2 ↓ 3: 9.8 ↓ 4: 10.3 ↓ 5: 10.4 ↑</p>	<p>1: 9.1 → 2: *10.5 ↘ 3: 10.0 ↘ 4: 10.1 → 5: 10.2 → 6: 9.8 ↗ 7: *10.7 ↗ 8: *10.5 ↘ 9: 10.3 ↑ 10: 10.3 →</p>	
Serie 48.0	Serie 98.0	
Total 145.0	Total 243.0	

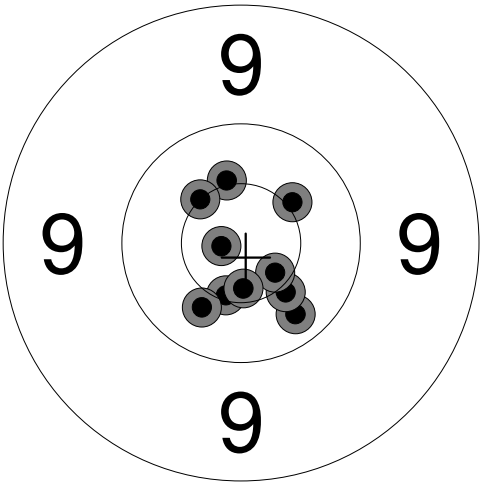
<p>Finale</p> 		
<p>1: 10.3 ↓ 2: *10.5 ↘ 3: *10.5 ↑ 4: *10.7 ↘ 5: *10.5 ↗ 6: *10.9 ↙ 7: *10.5 ↙ 8: *10.6 ↓ 9: *10.7 ↓ 10: 10.4 ↓</p>		
Serie 100.0		
Total 343.0		

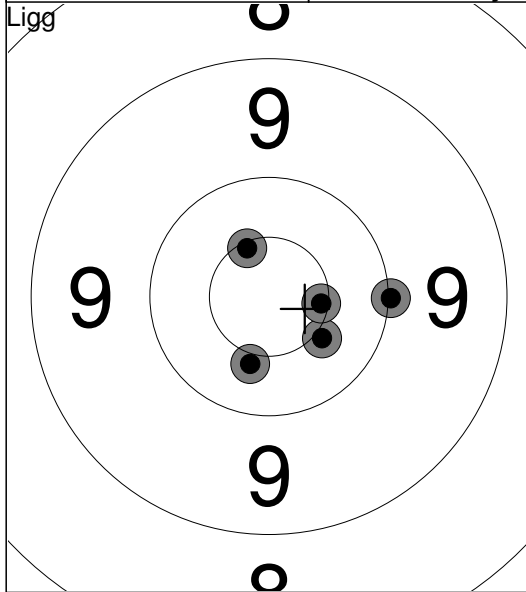

1: *10.5 ↘	
2: *10.6 →	
3: 10.4 ↓	
4: *10.6 ↗	
5: 10.0 →	
Serie 50.0	
Total 50.0	

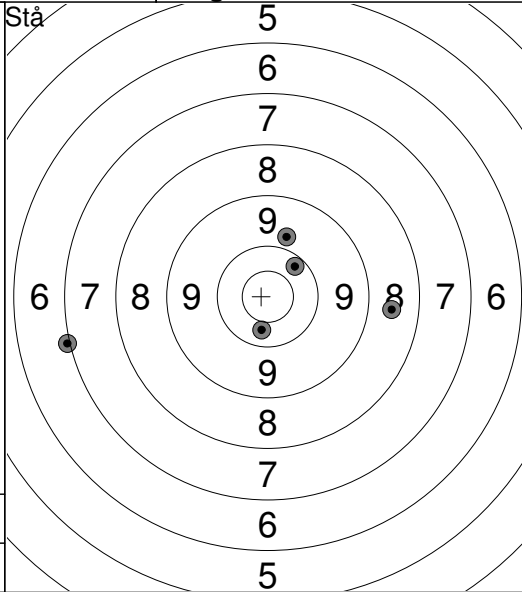

1: 10.4 ↓	
2: 9.8 ↑	
3: 8.6 →	
4: 10.2 ↗	
5: 7.0 ←	
Serie 44.0	
Total 94.0	

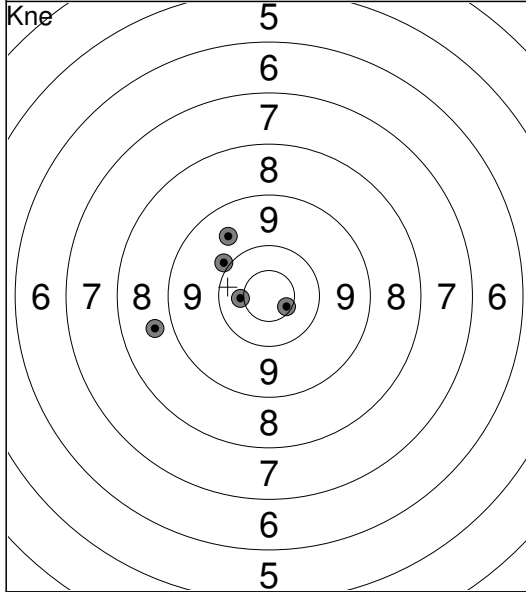

1: *10.6 ↘	
2: 8.7 ←	
3: 9.6 ↗	
4: *10.5 ←	
5: 9.9 ↖	
Serie 46.0	
Total 140.0	

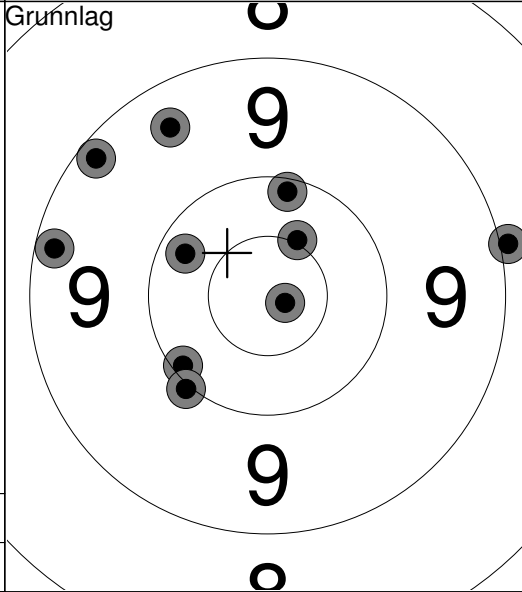

1: 9.0 →	
2: 10.1 ↙	
3: 9.4 ↗	
4: 9.2 ↖	
5: *10.9 →	
6: 9.2 ←	
7: 10.1 ↑	
8: 10.0 ↙	
9: 10.3 ←	
10: *10.5 ↗	
Serie 96.0	
Total 236.0	

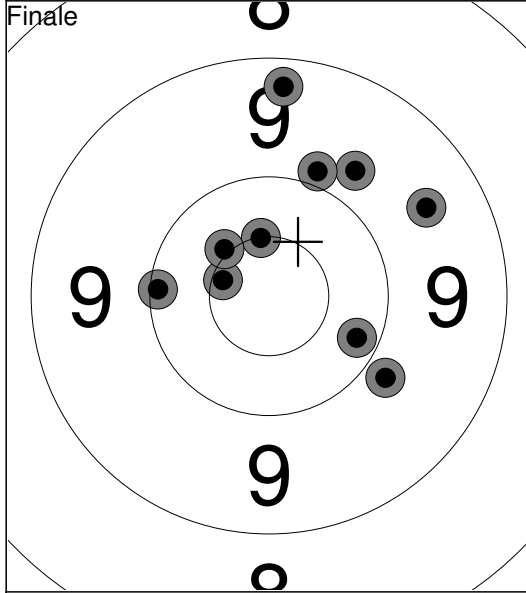

1: *10.5 ↑	
2: 9.5 ↗	
3: *10.6 ←	
4: 9.7 ↗	
5: 9.8 ↘	
6: 9.3 ↑	
7: *10.5 ↖	
8: 9.9 ↑	
9: 10.1 ←	
10: 10.2 ↘	
Serie 95.0	
Total 331.0	

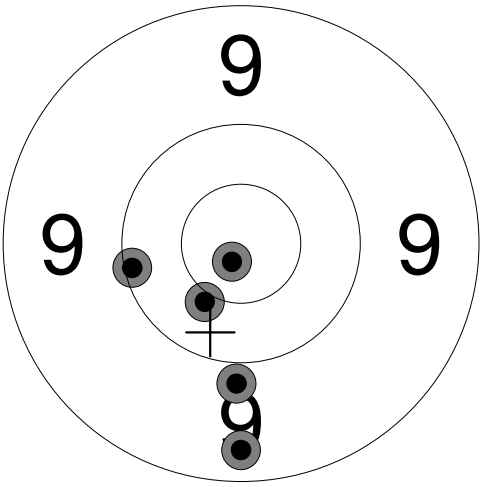
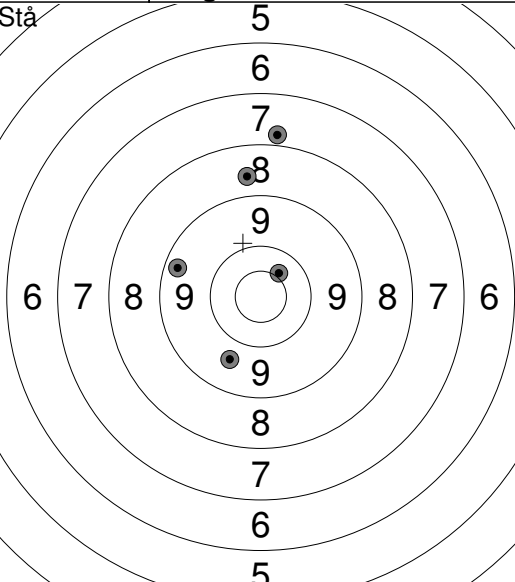
<p>Ligg</p> 	<p>Stå</p> 	<p>1: 8.6 ↑ 2: 7.8 ↑ 3: 9.3 ← 4: 10.4 ↗ 5: 9.7 ↓</p>
Serie 48.0	Serie 43.0	
Total 48.0	Total 91.0	

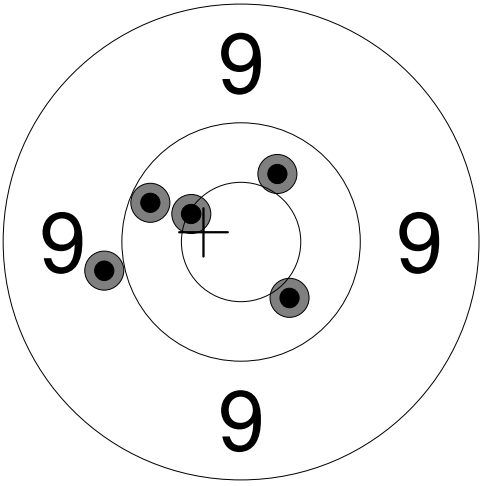
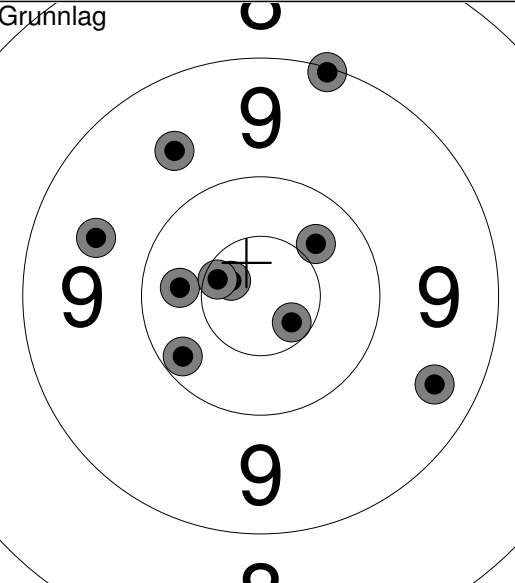
<p>Kne</p> 	<p>Grunnlag</p> 	<p>1: 9.1 ↑ 2: 10.2 ↙ 3: 9.4 → 4: 10.3 ← 5: *10.8 ↘ 6: *10.6 ↘ 7: 9.6 ↑ 8: *10.7 ↘ 9: 10.4 ↗ 10: 9.6 ←</p>
Serie 49.0	Serie 96.0	
Total 140.0	Total 236.0	

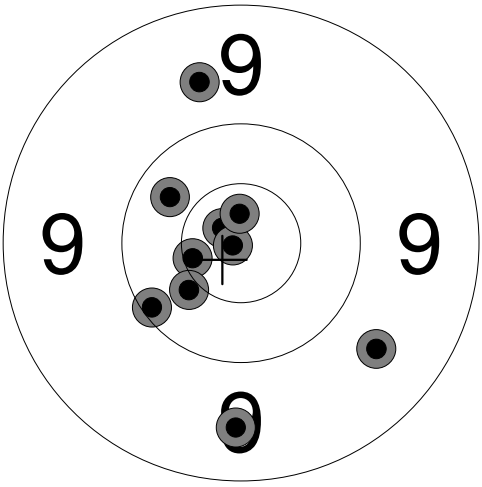
<p>Finale</p> 	<p>1: 9.6 ↑ 2: 10.3 ↘ 3: 9.5 ↓ 4: *10.6 ← 5: *10.8 ↘ 6: 10.4 ↙ 7: 10.1 ← 8: 9.6 ↘ 9: *10.9 ← 10: *10.8 ↑</p>	
Serie 97.0		
Total 333.0		

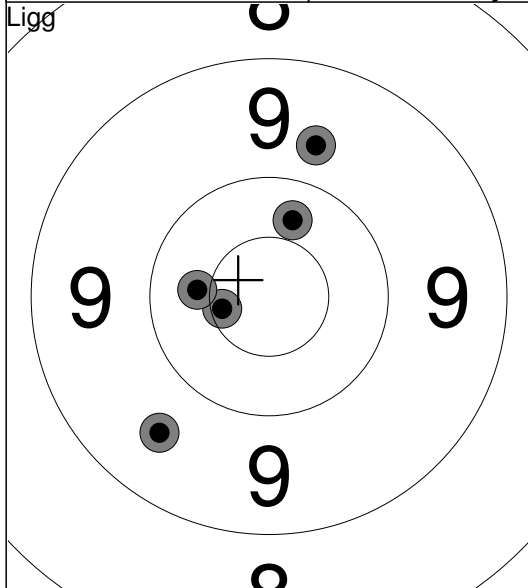

1:	9.6	↘	
2:	*10.6	↙	
3:	10.4	↗	
4:	10.4	↙	
5:	9.7	↗	
Serie		48.0	
Total		48.0	

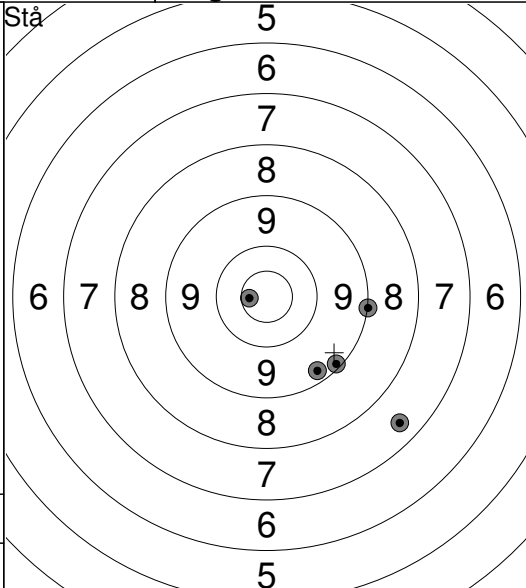

1:	*10.7	↙	
2:	7.4	↘	
3:	9.3	↘	
4:	9.0	→	
5:	9.1	↘	
Serie		44.0	
Total		92.0	

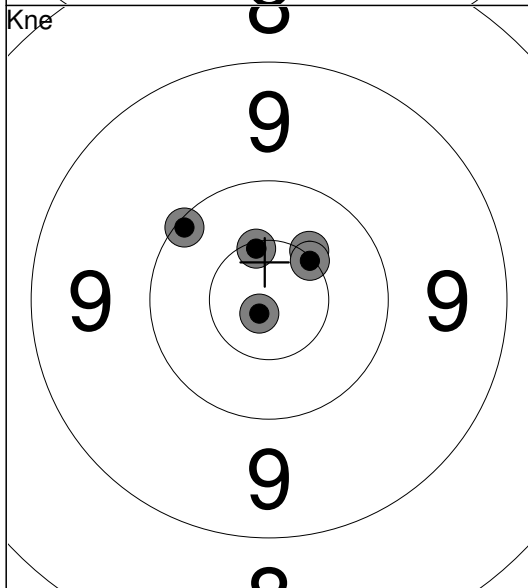

1:	*10.5	↗	
2:	*10.6	↗	
3:	10.1	↙	
4:	*10.6	↗	
5:	*10.9	↘	
Serie		50.0	
Total		142.0	

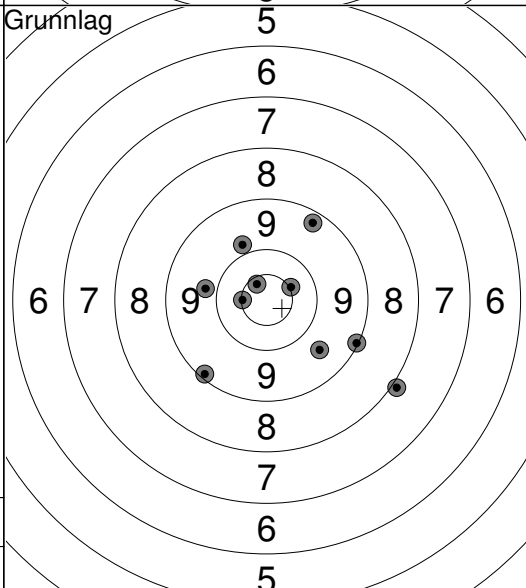

1:	7.9	↘	
2:	9.8	↙	
3:	9.1	↗	
4:	9.6	↘	
5:	9.3	↗	
6:	9.8	↗	
7:	*10.5	→	
8:	9.1	↘	
9:	*10.6	↙	
10:	*10.7	↗	
Serie		91.0	
Total		233.0	

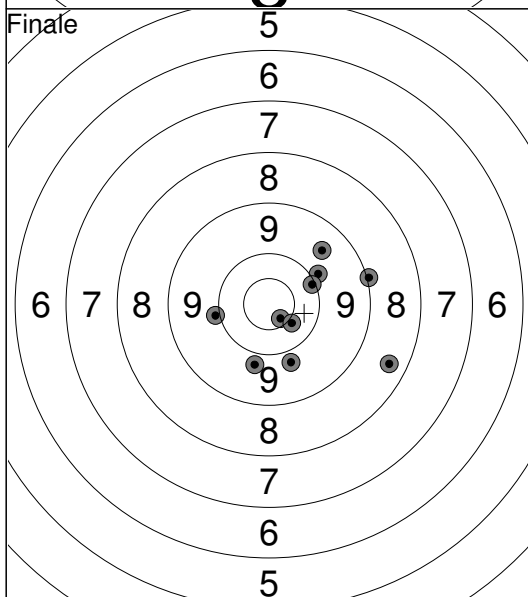

1:	8.4	↗	
2:	9.8	↘	
3:	*10.7	↘	
4:	9.9	↗	
5:	*10.5	↘	
6:	9.0	→	
7:	10.1	↗	
8:	9.5	↗	
9:	9.8	↘	
10:	9.9	↙	
Serie		92.0	
Total		325.0	